

ANNUAL HOMEOWNER RESPONSIBILITIES

Make sure downspouts are in place and extend away from basement walls.

Clear any debris from swales (concrete or grass) and ensure they are draining as per design.

Ensure storm water is directed away from the home and from neighbouring properties to the swale or street.

Check sump pump discharge lines regularly to ensure proper operation.

Check your yard on an annual basis to maintain grade. Fill any areas of settlement to avoid improper drainage and ensure the ground slopes away from the house on all sides.

Should the sanitary sewer back up in your basement, do not flush the toilet or turn on any taps; this will only cause further flooding.



CITY RESPONSIBILITIES

Ensure manholes are inspected for obstructions.

Regularly check storm water management facility inlets and outlets for proper weed control and removes any blockages.

Clean and inspect catch basin barrels and grates on a regular basis.

Ensure the sanitary sewer system is flushed and inspected regularly.

Maintain all streets by sweeping to keep gravel and debris out of the storm sewer.

Check manholes for blockage if homeowners are experiencing sanitary sewer backup.



BEAUMONT

INFRASTRUCTURE DEPARTMENT

City of Beaumont
Lot Grading

5600-49 Street

Beaumont, AB T4X 1A1

Phone: (780) 929-4314

E-mail: lotgrading@beaumont.ab.ca

Website Address: www.beaumont.ab.ca

CITY OF BEAUMONT

MAINTAINING YOUR GRADE

A GUIDE TO EFFECTIVE YARD DRAINAGE



CAUSES OF FLOODING

Apart from cracks in your foundation, basements can flood during a storm for two reasons:

1. Storm water drains too quickly into the weeping tile adjacent to the lower part of the basement footings causing it to seep in around the walls and up through the floor.
2. Excess drainage from weeping tiles in older areas of city will overload the sewer causing sewage backup through basement drains.

10mm of rain on the roof of a 110 m² (1184 ft²) bungalow equals 1100 litres (242 gallons) of runoff.

FOUR WAYS TO STAY DRY

1. INSTALL FLOOD-PROOFING DEVICES



If your home drainage system or the neighbourhood drainage system overloads, rainwater and sewage can still be kept from backing up into your basement by installing one or more flood proofing devices such as a sump pump (pictured at left) or backflow preventer. Each installation is unique and some devices require a plumbing permit, so speak to a qualified contractor before proceeding with installation.

2. MAINTAIN YOUR GRADE AND SWALES

If the land around your home slopes towards your foundation, rainwater heads to the weeping tile and can overload your home's drainage system.

Ensure your grade slopes away from the foundation on all sides of your home and that any swales (concrete or grass) are free from debris and draining as per design.

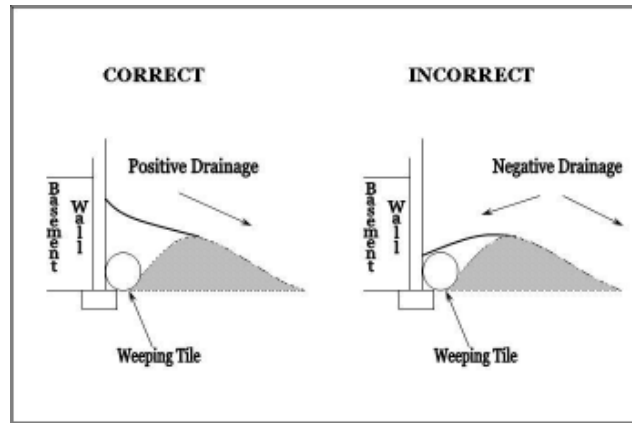

The land around your home is constantly settling so to ensure water stays away from your foundation, maintenance of your grade is critical.

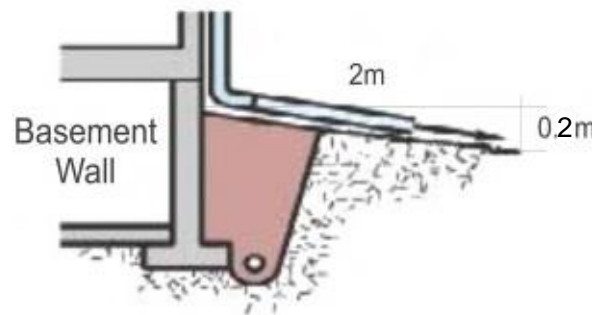

Proper grade and downspout extensions will prevent water from seeping into your foundation.

3. ENSURE PROPER DRAINAGE

Ensuring that water drains away from your home properly is extremely important. Rain and snow melt are collected by eaves troughs and channeled to the ground via downspouts. Downspouts are connected to an extension pipe and/or splash pad which carries the rainwater away from the house ensuring the water does not soak into the ground close to your home.

Downspout extensions should never be permanently removed or left in the vertical position.

The soil backfilled by your builder is of a lesser density than the rest of your lot and therefore this soil is more likely to allow water to pass through it; this soil is also more likely to settle and subside over time. If water is allowed to discharge from the downspouts close to the basement wall, it will work its way down to the foundation and will have damaging effects. Ensure your downspouts are in place and pointed away from your foundation at all times.

4. INSPECT PLUMBING FIXTURES

Your home flood proofing devices and plumbing fixtures should be inspected on a regular basis to ensure proper operation. If they are leaking, speak with a qualified contractor about getting them repaired as soon as possible.



Inspect faucets on a regular basis to prevent leaks.